

KM-201B_H

SELF-CONTAINED CUBER WITH BUILT-IN STORAGE BIN

Item # _____

Project: _____

Qty: _____

*AutoCad available on KCL

KM-201B_H

9/12

Item # 13238

CUBER DIMENSIONS W x D x H

KM-201B_H
24 x 28 x 39*
*with 6" legs





KM-201BAH

Air-Cooled
Shown

KM-201BWH

Water-Cooled

- Up to 215 lbs. of ice production per 24 hours
- Built-in 80 lbs. ice storage
- Individual crescent cube
- Durable stainless steel exterior
- Ice bin opening is ADA compliant
- CycleSaver® Design 
- EverCheck® alert system 
- Stainless steel evaporator
- Removable air filter (Air-cooled model only)
- R-404A Refrigerant

* The KM-201BAH is ENERGY STAR qualified.

Warranty

Valid in United States, Canada, Puerto Rico, & U.S. Territories. Contact factory for warranty in other countries.

Three Year - Parts & Labor on entire machine.

Five Year - Parts & Labor on: Evaporator.

Five Year - Parts on: Compressor, air-cooled condenser coil.



© HOSHIZAKI AMERICA, INC.

618 Hwy. 74 S., Peachtree City, GA 30269

TEL 1-800-438-6087

FAX 1-800-345-1325

www.hoshizaki.com



HOSHIZAKI

SELF-CONTAINED CUBER WITH BUILT-IN STORAGE BIN

KM-201B_H

DIMENSIONS
W x D x H
KM-201B_H
24 x 28 x 39"
*with 6" legs

- Air-cooled
- Water-cooled

AIR-COOLED

| | | | |
|-----------------|-----|-----|------------|
| Water Temp ° F. | 50° | 70° | 90° |
| Air Temp ° F. | 70° | 201 | 190 |
| | 80° | 193 | 177 |
| | 90° | 190 | 165 |

WATER-COOLED

| | | | |
|-----------------|-----|-----|------------|
| Water Temp ° F. | 50° | 70° | 90° |
| Air Temp ° F. | 70° | 215 | 205 |
| | 80° | 207 | 192 |
| | 90° | 205 | 181 |

UTILITY CONSUMPTION

| Model Number | Ice Production Per Cycle | | KWH per 100 LBS. 90/70 | Potable Water Gal. per 100 lbs. | Condenser Water Gal. per 100 lbs. |
|--------------|--------------------------|-------|------------------------|---------------------------------|-----------------------------------|
| | Lbs. | Cubes | | | |
| KM-201BAH | 4 | 182 | 7.5 | 22.0 | N/A |
| KM-201BWH | 4 | 182 | 6.17 | 24.0 | 141.3 |

SPECIFICATIONS

| Model Number | Condenser | Amperage | Shipping Weight |
|--------------|--------------|----------|-----------------|
| KM-201BAH | Air-Cooled | 6.1 | 165 lbs. |
| KM-201BWH | Water-Cooled | 5.5 | 165 lbs. |

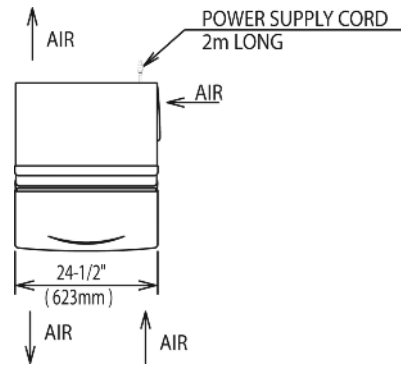

TOP VIEW - AIR-COOLED UNIT

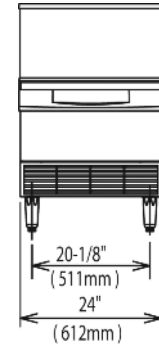

FRONT VIEW

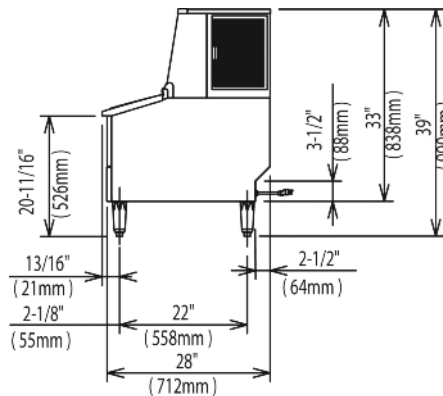

SIDE VIEW
(LOUVERS ON AIR-COOLED UNIT ONLY)

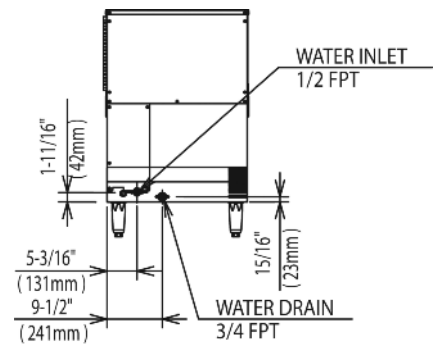

BACK VIEW - AIR-COOLED UNIT

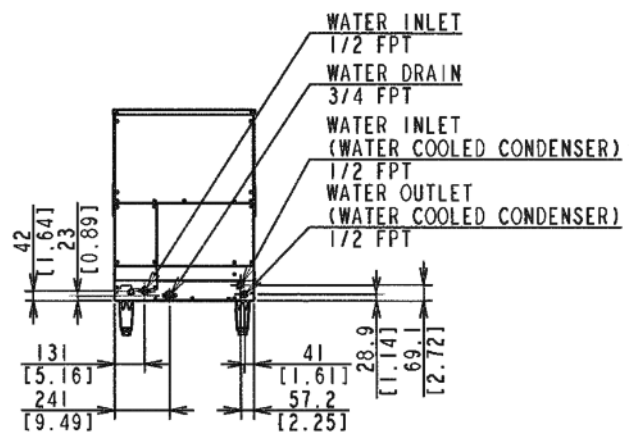

BACK VIEW / AIR-COOLED UNIT

ELECTRICAL & PLUMBING/KM-201BWH

- 115V/60/1
- 15 amp Max Fuse/HACR Breaker Size
- 3/8" OD copper or equivalent independent potable water supply
- 3/4" FPT independent drain connection
- 1/2" FPT water inlet



© HOSHIZAKI AMERICA, INC.

618 Hwy. 74 S., Peachtree City, GA 30269

OPERATING LIMITS

- Ambient Temp Range 45 - 100°F
- Water Temp Range 45 - 90°F
- Water Pressure 10 - 113psig
- Voltage Range 104 - 127V

SERVICE

- Panels easily removed and all components accessible for service.
- Removable/cleanable air filters (Air-cooled model only)

TEL 1-800-438-6087

FAX 1-800-345-1325

www.hoshizaki.com

Printed in U.S.A.

